

Sliding rail assembly procedure

1. Disassemble the slide rail

- Features:
1. 3-sections, ball-bearing easy-mount design.
 2. pull-out lock
 3. load rating 130lbs up
 4. 0.5" (12.7mm) thickness
 5. 1.8" (46.7mm) height
 6. max. ext. to 38" long

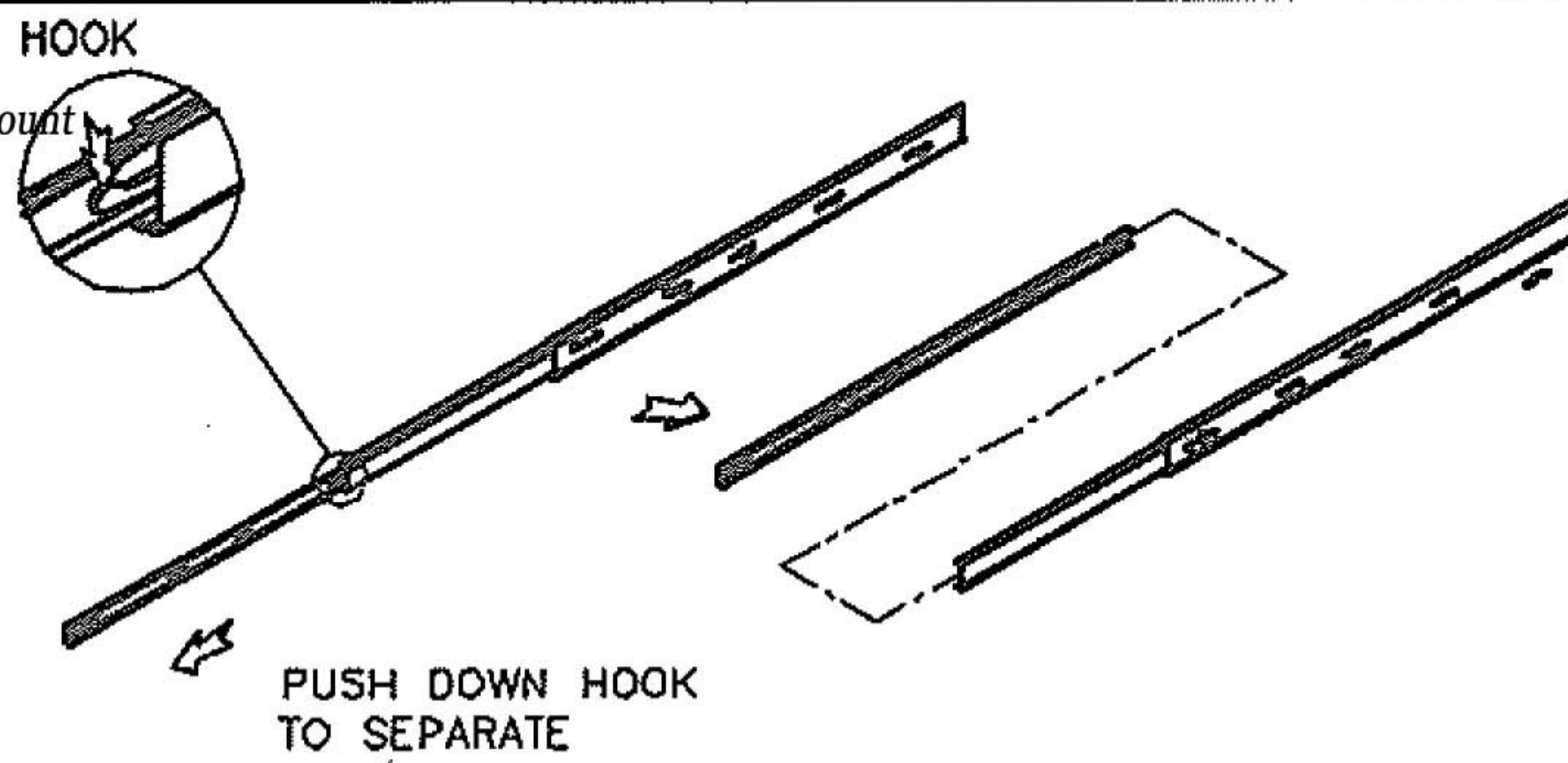

2. Assemble inner rail to chassis

3 hardware bags included:

Fasten 8 screws to fix inner rail on chassis

- bag1: four adjustable brackets (M5 screw hole)
 bag2: Ten #10-32 3/8" standard screws
 bag3: 16* M5x10mm Metric screws
 20* M4x6mm
 10* M4 washer

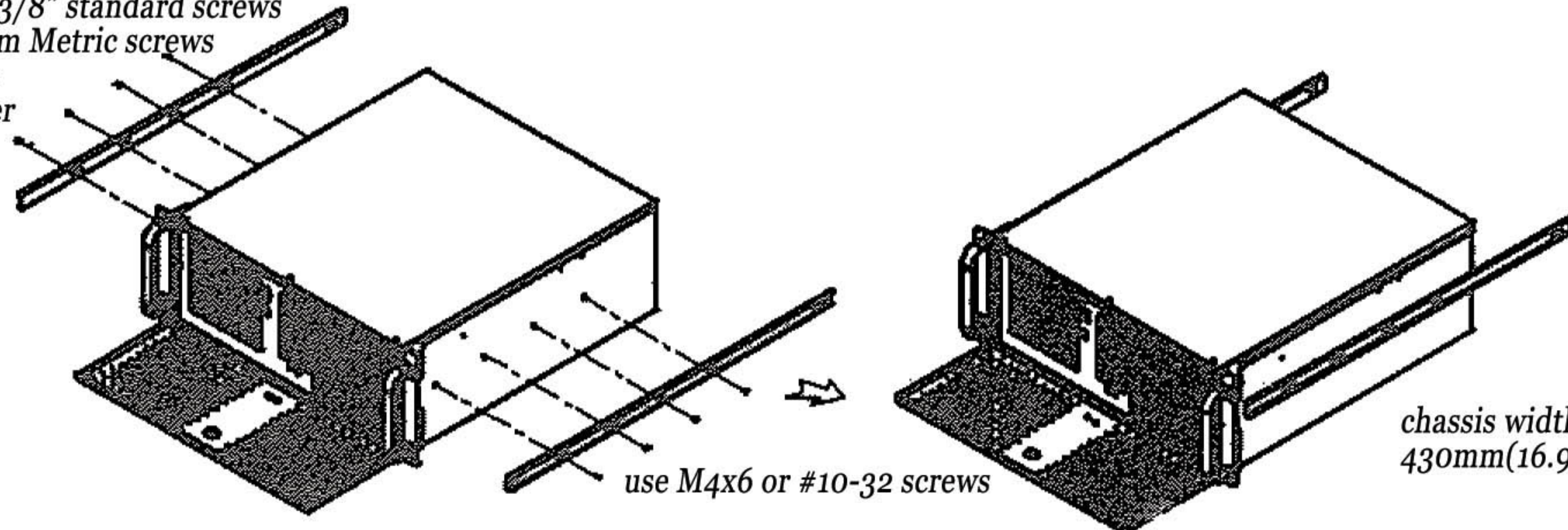

3. Fasten L shape & out piece of rail together

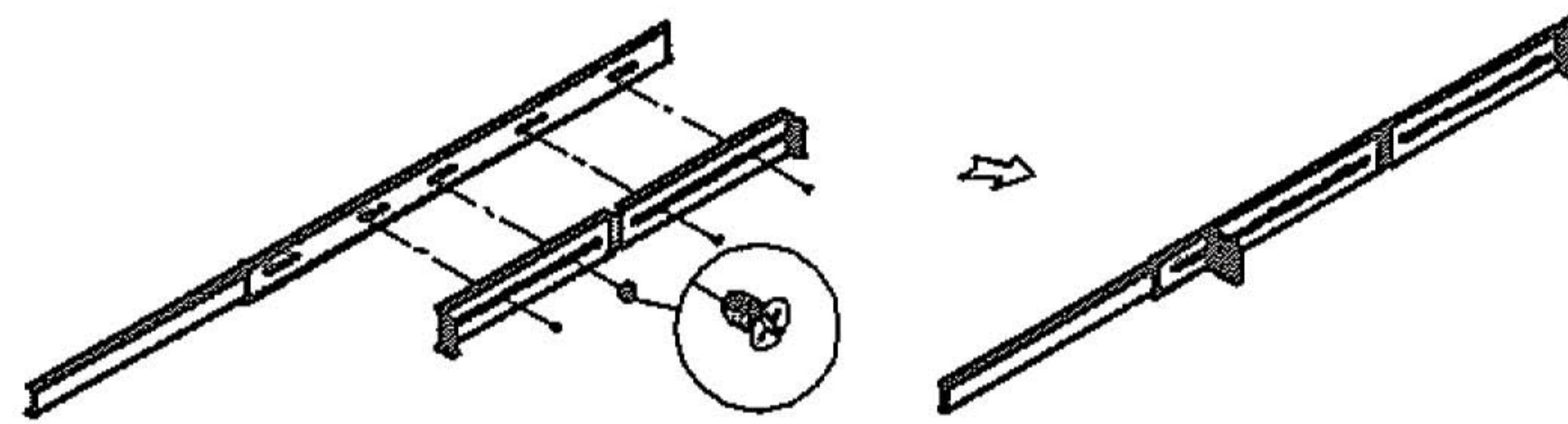

mount the L-brackets w/M4x6 to the tapped holes on outer rails

4. Mount L shape & external rail to rack frame

TYPE A

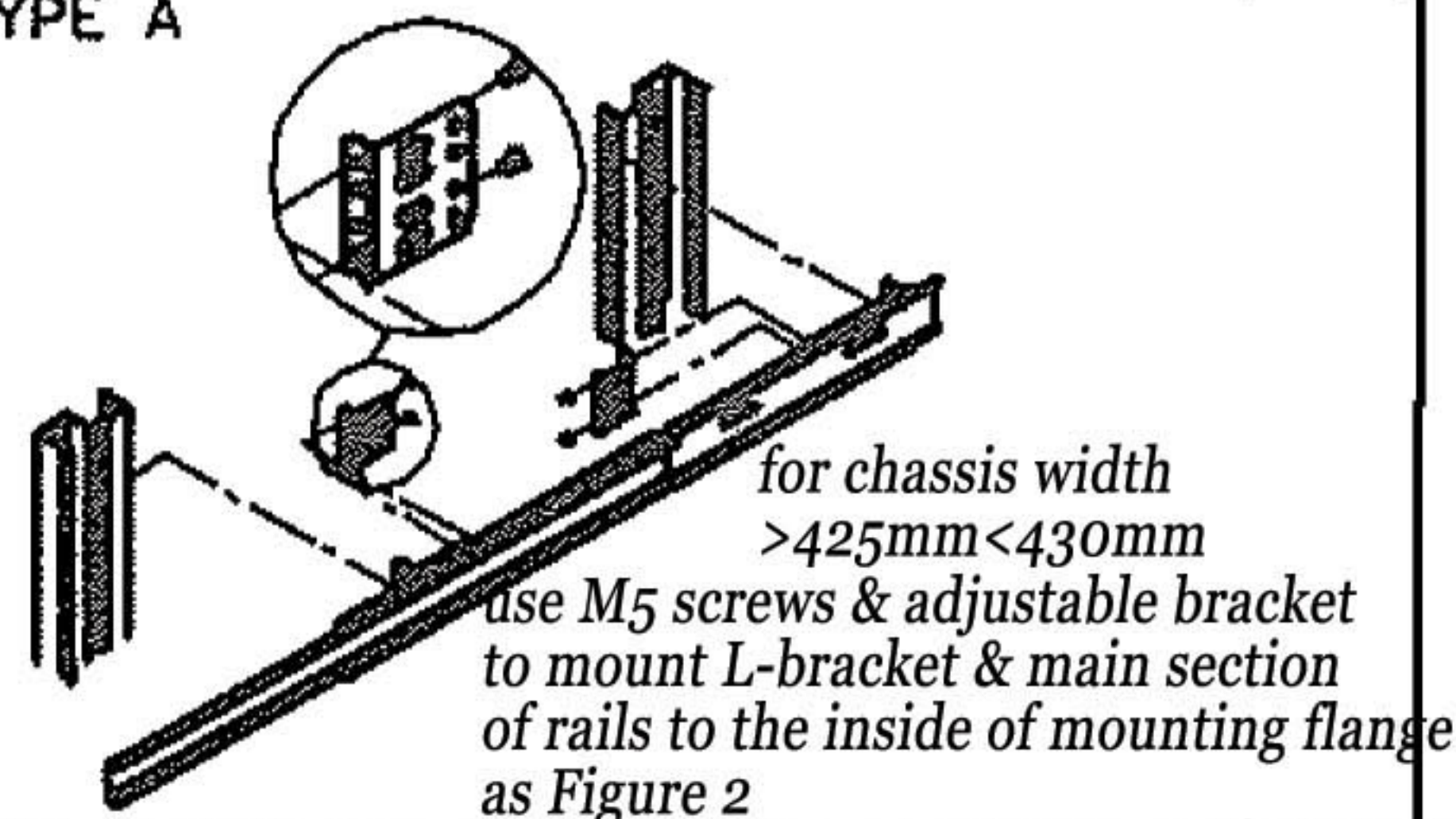

TYPE B

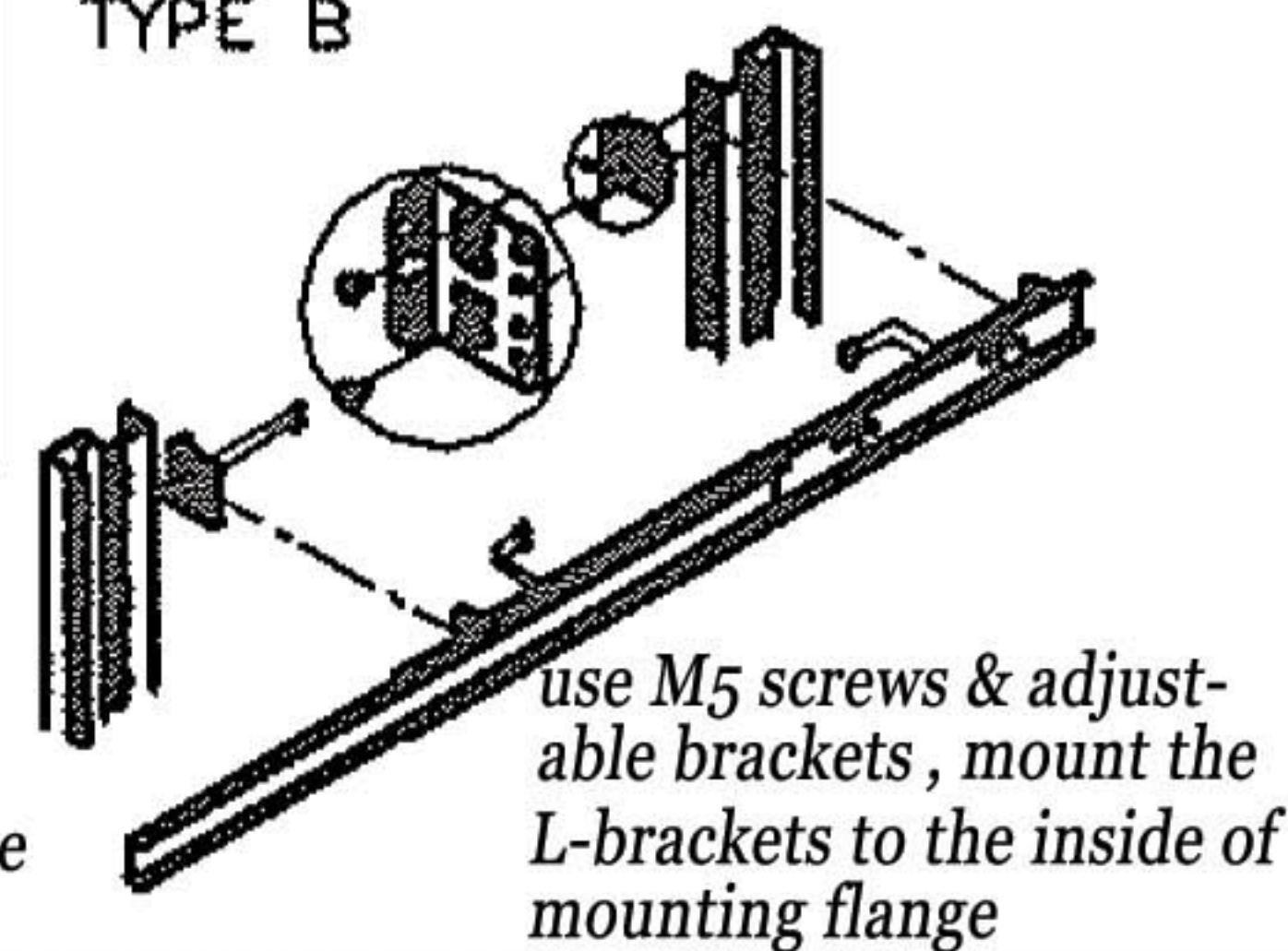

TYPE C

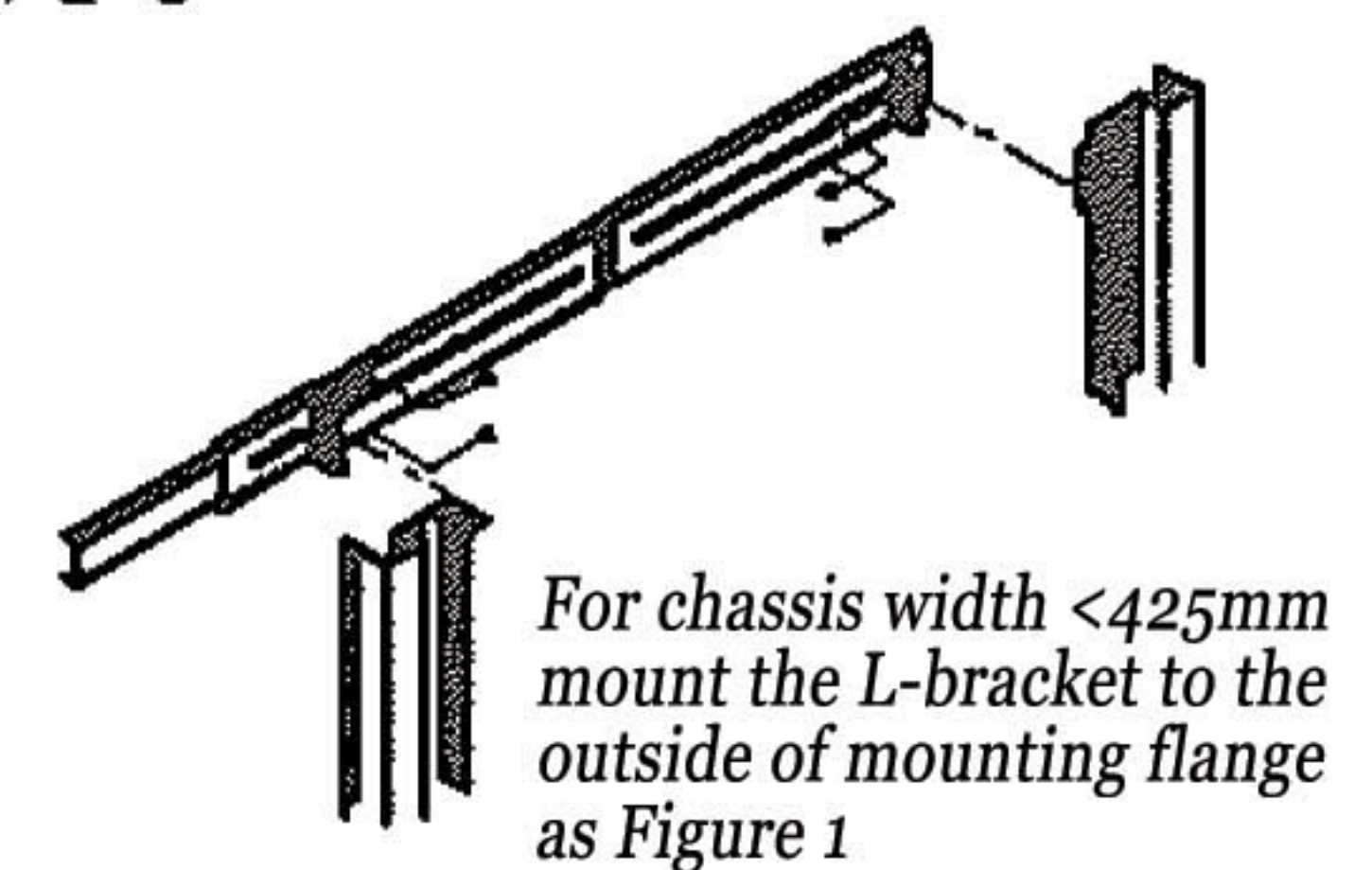

5. Insert chassis to frame

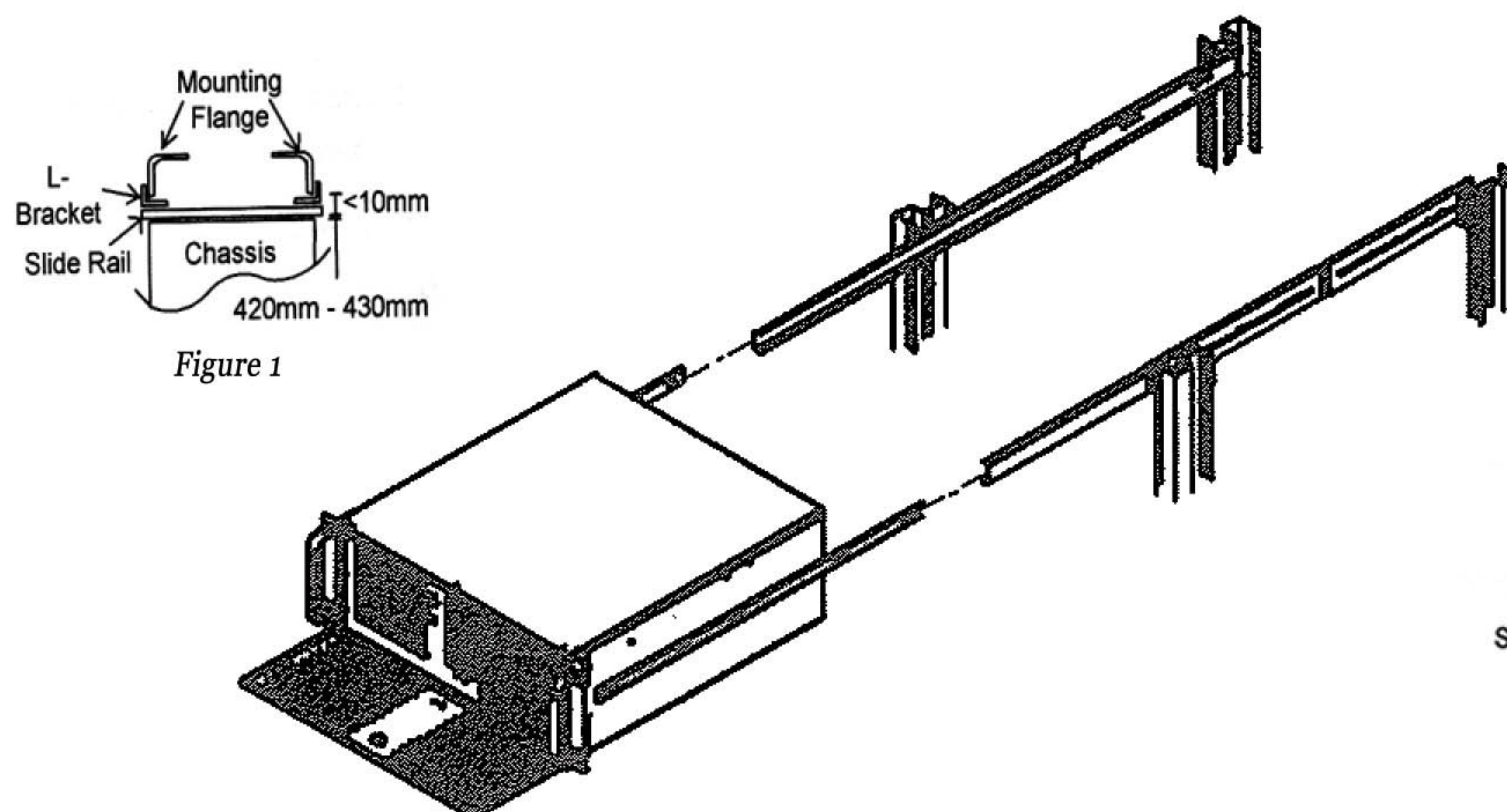

NOTES :

- 1. MATERIAL: HIGH STRENGTH CRS
- 2. BALL BEARING: LOW CARBON STEEL
- 3. LUBRICATION: EXTREME PRESURE POLYMER GREASER
- 4. FINISH: ELECTRO-ZINC PLATED
- 5. TENSILE: 1.2 ± 4 kgs/pc
- 6. TOLERANCE: XX ± 0.30
 X ± 0.76
 HOLES ± 0.15
 ANGLE 1°
- 7. NOMINAL LOAD RATING: 130 Lbs

| REV | DATE | LOC | DESCRIPTION | BY |
|-----|------|-----|-------------|----|
| △ | | | | |

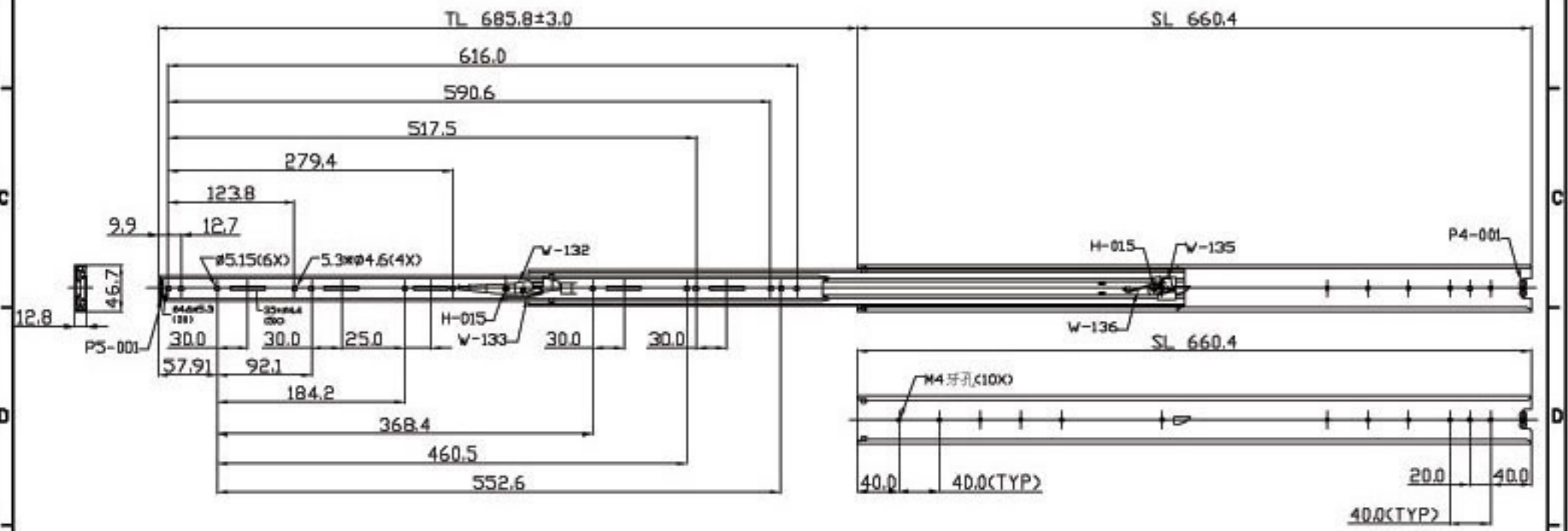

| | | | | |
|-------|---------------|-----------|--------------------|----------------------|
| DRW: | DATE: | MATERIAL: | NORCO RL-20 | |
| CRD: | CUSTOMER P/N: | FINISH: | | |
| APPD: | CUSTOMER: | SCALE: | MODEL: | TITLE: |
| | | UNIT: mm | P/N: 81033A-90 | |
| | | SCALE: | D/N: | SHEET 1 OF 1 REV: 03 |